

# COMPACFOAM

## CF WINDOW CILL CONNECTION PROFILE SYSTEM (CF-FBA)

ECONOMICAL AND STURDY.



The CF window cill connection profile system replaces conventional PVC-U window cill connection profiles. The low thermal conductivity, lambda value, of COMPACFOAM, means that condensation and mold formation in the window cill connection area are a thing of the past. The strength of the CF-window cill connection profile enables the aluminium cill pressings to be easily attached using suitable window cill screws (details on request) If a PVC-U external surface is bonded to the COMPACFOAM there is no alteration to the fixing detail required for attaching the aluminium cill pressing.

### OPTIONS AND BENEFITS:

- Standard length 2350mm, other lengths available to order up to a maximum of 6000mm.
- Milled to fit with a range of standard profile systems. Specials on request
- Available in sheets 2350mm x 780mm and in a range of thicknesses.

CAN ALSO HAVE A PVC-U (in Grey or White) LAYER BONDED TO ONE FACE

READILY AVAILABLE FOR WINDOW PROFILE SYSTEMS FROM Aluplast, Profine, Rehau, Veka and many more

SEALING WITH MS POLYMER AND LIQUID SEALING MEMBRANE, ACCORDING TO APPLICATION.

TIMBER-FREE MATERIAL

WILL NOT ROT

WITHSTANDS MOISTURE AND THE EFFECTS OF FREEZE THAW

IMPROVED INSULATION

### Technical data for **CF 100**

Thicknesses	40 mm	45 mm	50 mm	55 mm	60 mm
U-Value (W/m <sup>2</sup> K)	1,13	1,00	0,90	0,82	0,75
Window Cill Screws 4.5 x 35mm Screw extraction base layer	413 N				
Packing Shims in mm	60x40	53x66			
Maximum glass panel load	283,80	376,00			
Fire class DIN 4102-1 / EN 13501-1	B1/E				

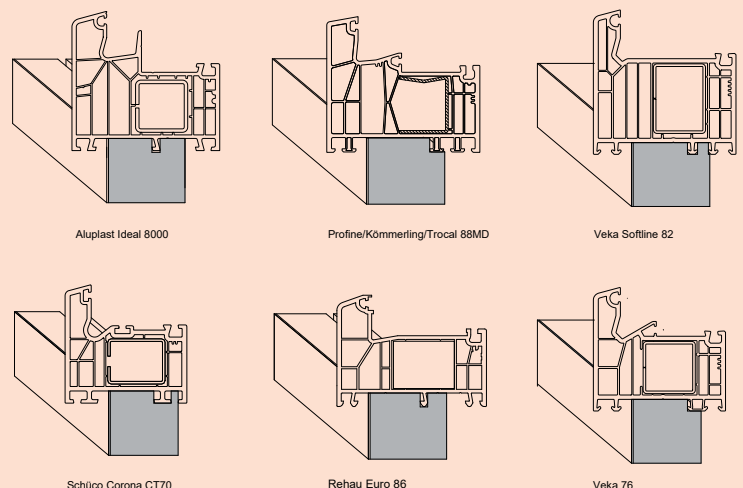

## Alternative window cill connection detail providing improved insulation, suitable for PVC profile systems

- 1 Window frame screw 7.5mm thread –  
no pre-drilling required in the window Cill connection profile.  
Fixing spacing and screw length according to design requirements.
- 2 Joint bonding with MS Polymer adhesive or adhesive tape
- 3 CF window cill connection profile
- 4 The ends of the aluminium cill pressing must be sealed to the substrate.
- 5 Cill Pressing fixing screw
- 6 Frame packers
- 7 Gaps between packers need to be filled with suitable insulation
- 8 Secondary Seal to provide a backup if the primary external seal fails
- 9 Screw 5.5mm thread
- 10 Optional PVC top layer

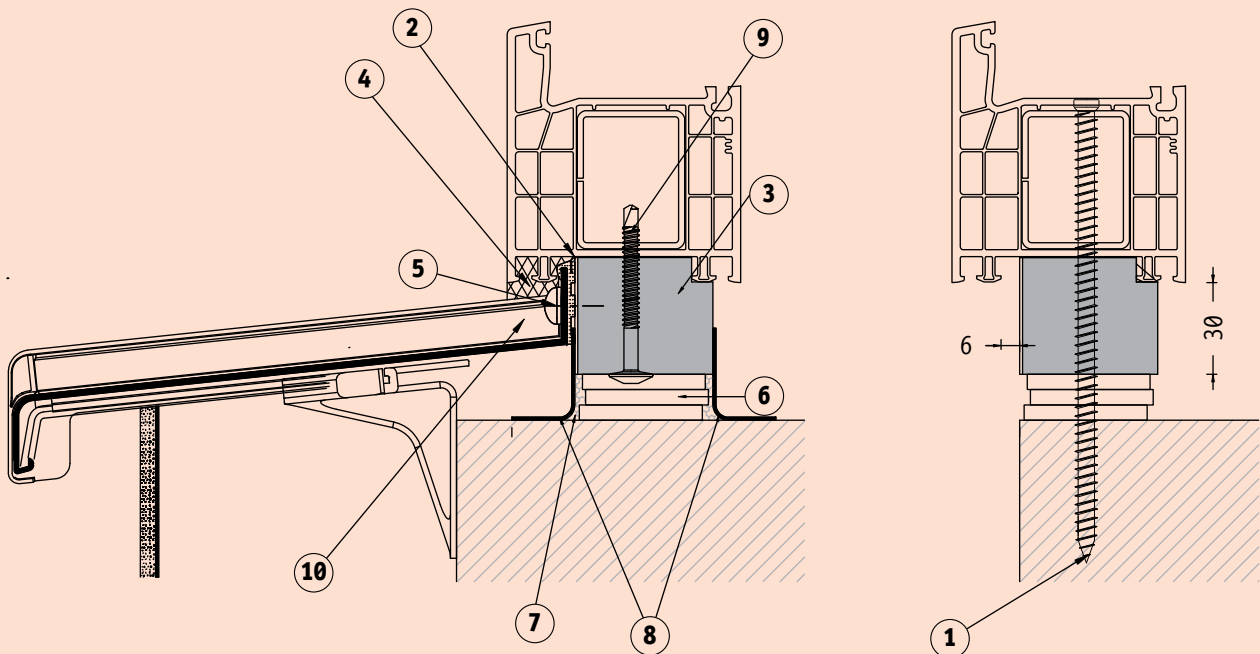

### Your contact to COMPACFOAM

COMPACFOAM Head Office and Production:

Resselstraße 7 - 11

2120 Wolkersdorf, Österreich

Phone +43 (0) 2245 / 20 8 02

E-Mail: office@compacfoam.com

[www.compacfoam.com](http://www.compacfoam.com)

